

1260 VXI SWITCHING CARD

1260-138A MULTIPLEXER PLUG-IN

PUBLICATION NO. 980824-138A

RACAL INSTRUMENTS

United States

(Corporate Headquarters and Service Center)
4 Goodyear Street, Irvine, CA 92618
Tel: (800) 722-2528, (949) 859-8999; Fax: (949) 859-7139
5730 Northwest Parkway Suite 700, San Antonio, TX 78249
Tel: (210) 699-6799; Fax: (210) 699-8857

Europe

(European Headquarters and Service Center)
18 Avenue Dutartre, 78150 LeChesnay, France
Tel: +33 (0)1 39 23 22 22; Fax: +33 (0)1 39 23 22 25
29-31 Cobham Road, Wimborne, Dorset BH21 7PF, United Kingdom
Tel: +44 (0) 1202 872800; Fax: +44 (0) 1202 870810
Via Milazzo 25, 20092 Cinisello B, Milan, Italy
Tel: +39 (0)2 6123 901; Fax: +39 (0)2 6129 3606
Technologie Park, Friedrich Ebert Strasse, 51429 Bergisch Gladbach, Germany
Tel: +49 (0) 2204 844200; Fax: +49 (0) 2204 844219

info@racalstruments.com
sales@racalstruments.com
helpdesk@racalstruments.com
<http://www.racalstruments.com/>



PUBLICATION DATE: November 10, 2004

Copyright 1999 by Racal Instruments, Inc. Printed in the United States of America. All rights reserved.
This book or parts thereof may not be reproduced in any form without written permission of the publisher.

THANK YOU FOR PURCHASING THIS RACAL INSTRUMENTS PRODUCT.

For this product, or any other Racal Instruments product that incorporates software drivers, you may access our web site to verify and/or download the latest driver versions. The web address for driver downloads is:

<http://www.racalinstruments.com/downloads>

If you have any questions about software driver downloads or our privacy policy, please contact us at

info@racalinstruments.com.

WARRANTY STATEMENT

All Racal Instruments, Inc. products are designed and manufactured to exacting standards and in full conformance to Racal's ISO 9000/2000 procedures.

This warranty does not apply to defects resulting from any modification(s) of any product or part without Racal Instruments express written consent, or misuse of any product or part. The warranty also does not apply to fuses, software, non-rechargeable batteries, damage from battery leakage, or problems arising from normal wear, such as mechanical relay life, or failure to follow instructions.

This warranty is in lieu of all other warranties, expressed or implied, including any implied warranty of merchantability or fitness for a particular use. The remedies provided herein are buyer's sole and exclusive remedies.

For the specific terms of your standard warranty, or optional extended warranty or service agreement, contact your Racal customer service advisor. Please have the following information available to facilitate service.

1. Product serial number
2. Product model number
3. Your company and contact information

You may contact your customer service advisor by:

E-Mail:	Helpdesk@racalinstruments.com	
Telephone:	+1 800 722 3262	(USA)
	+44(0) 8706 080134	(UK)
Fax:	+1 949 859 7309	(USA)
	+44(0) 1628 662017	(UK)

RETURN of PRODUCT

Authorization is required from Racal Instruments before you send us your product for service or calibration. Call your nearest Racal Instruments support facility. A list is located on the last page of this manual. If you are unsure where to call, contact Racal Instruments, Inc. Customer Support Department in Irvine, California, USA at 1-800-722-3262 or 1-949-859-8999 or via fax at 1-949-859-7139. We can be reached at: helpdesk@racalstruments.com.

PROPRIETARY NOTICE

This document and the technical data herein disclosed, are proprietary to Racal Instruments, and shall not, without express written permission of Racal Instruments, be used, in whole or in part to solicit quotations from a competitive source or used for manufacture by anyone other than Racal Instruments. The information herein has been developed at private expense, and may only be used for operation and maintenance reference purposes or for purposes of engineering evaluation and incorporation into technical specifications and other documents which specify procurement of products from Racal Instruments.

DISCLAIMER

Buyer acknowledges and agrees that it is responsible for the operation of the goods purchased and should ensure that they are used properly and in accordance with this handbook and any other instructions provided by Seller. Racal Instruments products are not specifically designed, manufactured or intended to be used as parts, assemblies or components in planning, construction, maintenance or operation of a nuclear facility, or in life support or safety critical applications in which the failure of the Racal Instruments product could create a situation where personal injury or death could occur. Should Buyer purchase Racal Instruments product for such unintended application, Buyer shall indemnify and hold Racal Instruments, its officers, employees, subsidiaries, affiliates and distributors harmless against all claims arising out of a claim for personal injury or death associated with such unintended use.

FOR YOUR SAFETY

Before undertaking any troubleshooting, maintenance or exploratory procedure, read carefully the **WARNINGS** and **CAUTION** notices.



CAUTION
RISK OF ELECTRICAL SHOCK
DO NOT OPEN



This equipment contains voltage hazardous to human life and safety, and is capable of inflicting personal injury.



If this instrument is to be powered from the AC line (mains) through an autotransformer, ensure the common connector is connected to the neutral (earth pole) of the power supply.



Before operating the unit, ensure the conductor (green wire) is connected to the ground (earth) conductor of the power outlet. Do not use a two-conductor extension cord or a three-prong/two-prong adapter. This will defeat the protective feature of the third conductor in the power cord.



Maintenance and calibration procedures sometimes call for operation of the unit with power applied and protective covers removed. Read the procedures and heed warnings to avoid “live” circuit points.

Before operating this instrument:

1. Ensure the proper fuse is in place for the power source to operate.
2. Ensure all other devices connected to or in proximity to this instrument are properly grounded or connected to the protective third-wire earth ground.

If the instrument:

- fails to operate satisfactorily
- shows visible damage
- has been stored under unfavorable conditions
- has sustained stress

Do not operate until, performance is checked by qualified personnel.

Racal Instruments

EC Declaration of Conformity

We

Racal Instruments Inc.
4 Goodyear Street
Irvine, CA 92718

declare under sole responsibility that the

**1260-138A Power Switch Plug In Module
P/N 407723**

conforms to the following Product Specifications:

Safety: EN 61010-1

EMC: EN50081-1
CISPR 11:1990/EN 55011 (1991): Group 1 Class A
IEC 801-2:1991/EN 50082-1 (1992): 4 kV CD, 8 kV AD
IEC 801-3:1984/EN 50082-1 (1992): 3 V/m, 27-500 MHz
IEC 801-4:1988/EN 50082-1 (1992): 1 kV

Supplementary Information:

The above specifications are met when the product is installed in a Racal Instruments Adapt-a-Switch Carrier with faceplates installed over all unused slots, as applicable. The carrier is installed in a certified mainframe.

The product herewith complies with the requirements of the Low Voltage Directive 73/23/EEC and the EMC Directive 89/336/EEC.

Irvine, CA, October 28, 1999

Quality Manager

This page was left intentionally blank.

Table of Contents

Chapter 1	1-1
SPECIFICATIONS	1-1
Introduction	1-1
Specifications	1-2
Ordering Information	1-4
Chapter 2	2-1
INSTALLATION INSTRUCTIONS.....	2-1
Unpacking and Inspection	2-1
Reshipment Instructions	2-1
Installation	2-2
Module Configuration	2-2
Configuration Relays	2-5
Analog Bus Relays	2-6
Connector Pin Assignments	2-6
Front Panel Connector	2-9
Mating Connectors.....	2-11
Chapter 3	3-1
MODULE OPERATION.....	3-1
Setting the Module Address	3-1
Operating Modes.....	3-2
Operating In Message-Based Mode	3-4
Channel Descriptors For The 1260-138A.....	3-4
Reply To The MOD:LIST? Command	3-5
Operating The 1260-138A in Register-Based Mode	3-5
Configuring Larger Multiplexers.....	3-8
Creating Very Large Multiplexers With the Analog Bus	3-9
1260-138A Example Code	3-11
Chapter 4	4-1
OPTIONAL ASSEMBLIES	4-1

Chapter 5 5-1

PRODUCT SUPPORT 5-1

 Product Support 5-1

 Reshipment Instructions 5-1

 Support Offices 5-2

List of Figures

Figure 1-1, The 1260-138A..... 1-1

Figure 2-1: Single Multiplexer Example (Channels 50 through 57).....2-2

Figure 2-2, Block Diagram of 1260-138A.....2-4

Figure 2-3, 1260-138A Module Configuration Block Diagram.2-5

Figure 2-4, 1260-138A Multiplexer Configuration Block Diagram.....2-5

Figure 2-5, Front-Panel Connector Pin Numbering 2-10

Figure 3-1, Front View – Module Addresses for 1 through 63-1

Figure 3-2 Front View – Module Addresses for 7 through 123-2

Figure 3-3, Message-Based Mode of Operation3-3

Figure 3-4, Register-Based Mode of Operation.....3-3

List of Tables

Table 2-1, Command Arguments for Interconnecting the Muxes2-5

Table 2-2, Command Arguments for Connecting to the Analog Bus 2-6

Table 2-3, 1260-138A Front-Panel Connections for J200 2-6

Table 3-1, Control Register Channel Assignments..... 3-7

This page was left intentionally blank.

Chapter 1

SPECIFICATIONS

Introduction

The 1260-138A is a plug-in switch module developed for the Racal Instruments 1260-100 Adapt-a-Switch Platform. The 1260-138A includes the following features:

- Standard Adapt-a-Switch plug-in design, providing for ease of replacement.
- Data-driven embedded descriptor, allowing immediate use with any Option-01T switch controller, regardless of firmware revision level.
- Capability of combining multiple multiplexers on-board to form large multiplexers.
- Analog bus for combining multiple 1260-138A plug-ins, to form very large multiplexers.

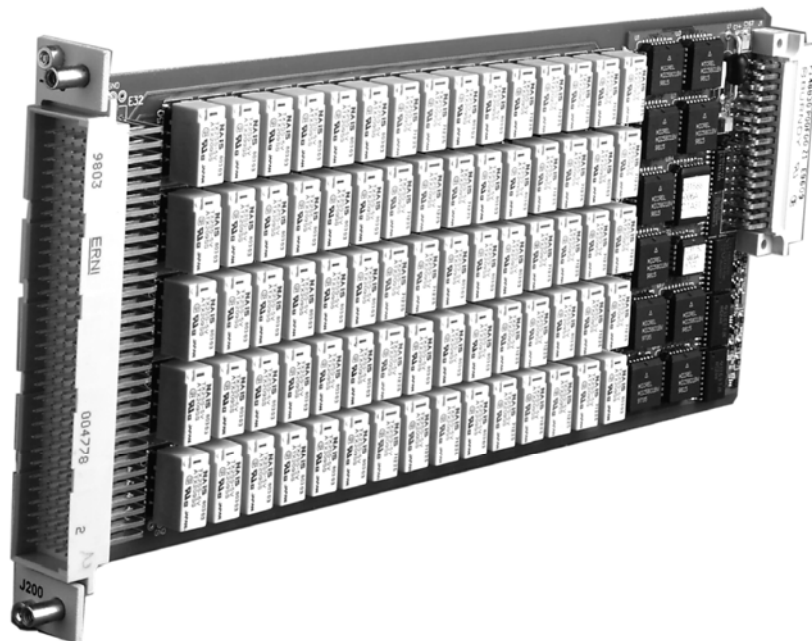

Figure 1-1, The 1260-138A

Specifications

Bandwidth (-3 dB)		
1 x 8		> 85 MHz
1 x 64		> 4 MHz
Insertion Loss (1 x 8)		
100KHz:		< 0.1 dB
1MHz:		< 0.2 dB
10MHz:		< 1.7 dB
30MHz:		< 1.7 dB
Isolation (1 x 8)		
100KHz:		> 88 dB
1MHz:		> 78 dB
10MHz:		> 44 dB
30MHz:		> 40 dB
Crosstalk (1 x 8)		
100KHz:		< -63 dB
1MHz:		< -63 dB
10MHz:		< -41 dB
30MHz:		< -34 dB
Switching Voltage		
AC		250 V, Max
DC		220 V, Max
Switching Current		
AC		2 A, Max
DC		2 A, Max
Switching Power		
AC		125 VA, Max
DC		60 W, Max
Path resistance		
	1 x 8:	500 m Ω
	1 x 40:	650 m Ω
	1 x 64:	800 m Ω
Thermal EMF		< 10 μ V
Capacitance		
	(1 x 8) Channel to Chassis	< 150 pF
	(1 x 8) Open Channel	< 5 pF
	(1 x 8) High to Low	< 110 pF
	(1 x 64) High to Low	< 400 pF
Insulation resistance		> 10 ⁹ Ω
Relay Settling Time		< 10 ms
Shock		30g, 11 ms, 1/2 sine wave

Vibration	0.013 in. P-P, 5-55 Hz
Bench Handling	4 in., 45°
Cooling	See 1260-100 cooling data
Temperature	
Operating	0°C to +55°C
Non-operating	-40°C to +75°C
Relative Humidity	85% + 5% non-condensing at < 30°C
Altitude	
Operating	10,000 feet
Non-operating	15,000 feet
Power Requirements	
+5 VDC	150mA + 30mA per energized relay (2A Max.)
MTBF	
MIL-HDBK-217E	183,169 hours
Bellcore	154,107 hours
Relay Life Expectancy	
Mechanical	100,000,000 operations
Electrical	100,000 operations at full rated load (resistive)
Weight	1.0 lb. (0.45 kg.)
Dimensions	4.5"H X 0.75"W X 9.5"D

Ordering Information

Listed below are part numbers for both the 1260-138A switch module and available mating connector accessories. Each 1260-138A uses a single mating connector.

ITEM	DESCRIPTION	PART #
1260-138A Switch Module	Switch Module, 8 (1X8) 2 Wire Mux, 2 A Consists of: P/N 405156 PCB Assembly P/N 980824-138A Manual	407723
160-pin Mating Connector	160 Pin Conn. Kit with pins	407664
Cable Assy. 6ft, Sleeved	160 Pin Cable Assy, 6 Ft, 24 AWG	407408-001
Additional Manual	1260-138A Manual	980824-138A

Chapter 2

INSTALLATION INSTRUCTIONS

Unpacking and Inspection

1. Before unpacking the switching module, check the exterior of the shipping carton for any signs of damage. All irregularities should be noted on the shipping bill and reported.
2. Remove the instrument from its carton, preserving the factory packaging as much as possible.
3. Inspect the switching module for any defects or damage. Immediately notify the carrier if any damage is apparent.
4. Have a qualified person check the instrument for safety before use.



CAUTION

**The instruments contains ESD-sensitive devices.
Open the package at an ESD-safe work station.**

Reshipment Instructions

1. Use the original packing material when returning the switching module to Racal Instruments for servicing. The original shipping carton and the instrument's plastic foam will provide the necessary support for safe reshipment.
2. If the original packing material is unavailable, wrap the switching module in an ESD shielding bag and use plastic spray foam to surround and protect the instrument.
3. Reship in either the original or a new shipping carton.

Installation

Installation of the 1260-138A Switching Module into a 1260-100/101 Adapt-a-Switch Carrier assembly is described in the "Installation" section of the 1260-100/101 Adapt-a-Switch Carrier manual.

For installation of the 1260-138A into a 1256 Switching System, refer to the 1256 User Manual.

Module Configuration

The 1260-138A contains eight 1x8 multiplexers, numbered from 0 through 7. Each multiplexer (mux) is made up of eight relays, referred to as channels. **Figure 2-1** shows an example of one of these multiplexers (multiplexer 5). In this example, the inputs are channels 50 through 57. The user may close one or more relays to connect the inputs to the common output.

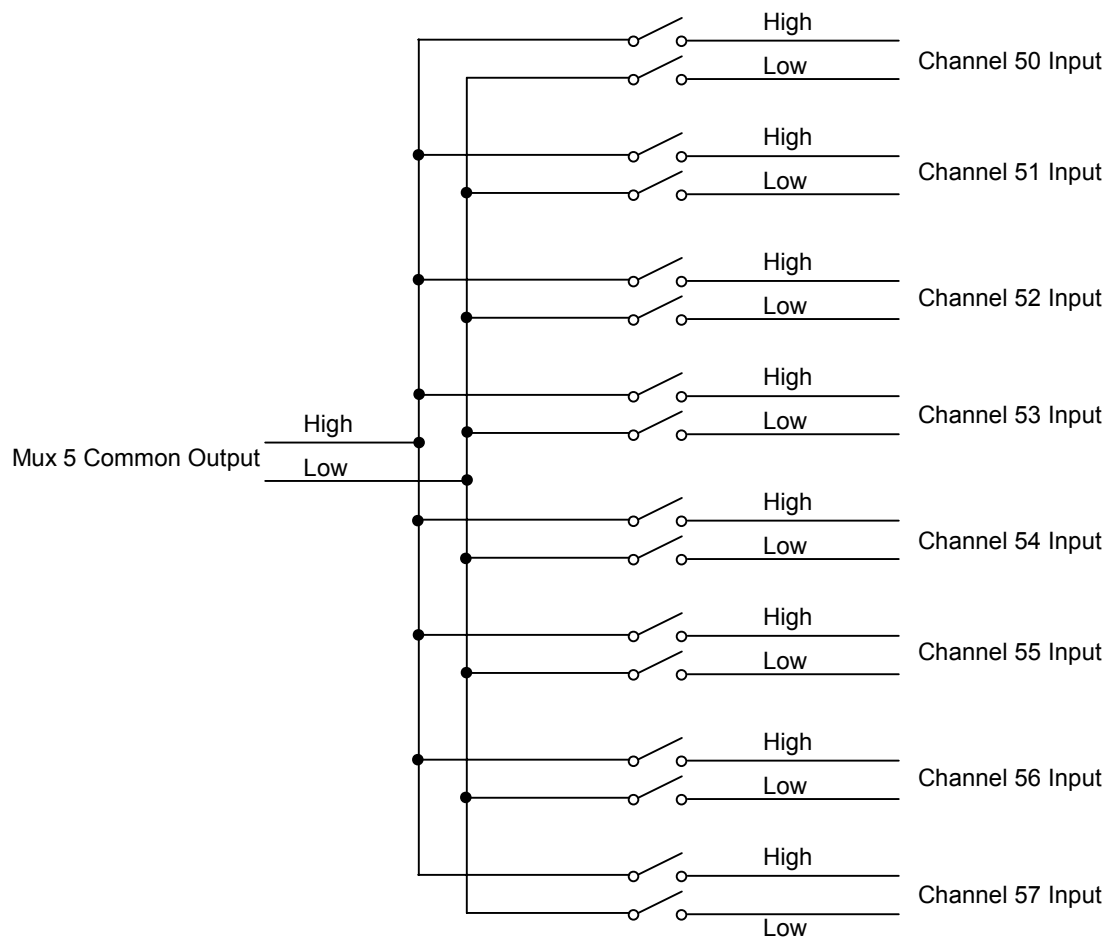

Figure 2-1: Single Multiplexer Example (Channels 50 through 57)

Since each channel is independently controlled, the user can simultaneously connect any combination of mux inputs to the common output of the same multiplexer.

For example, referring to **Figure 2-1**, the user may connect the channel 51 and channel 53 inputs to the common output by closing the channel 51 and channel 53 relays at the same time. Taking this concept further, the user could even close the relays for channels 50 through 57 all at the same time, connecting all of this multiplexer's inputs to its common output.

Figure 2-1 shows just one of the eight multiplexers on the 1260-138A. All eight multiplexers operate independently. For a block diagram of the entire 1260-138A, refer to **Figure 2-2**. When reviewing this diagram, keep in mind that the 1260-138A is a two-wire switch product (each relay has two poles). Most applications use one pole to switch the high side of a differential signal, and the other pole to switch the low side.

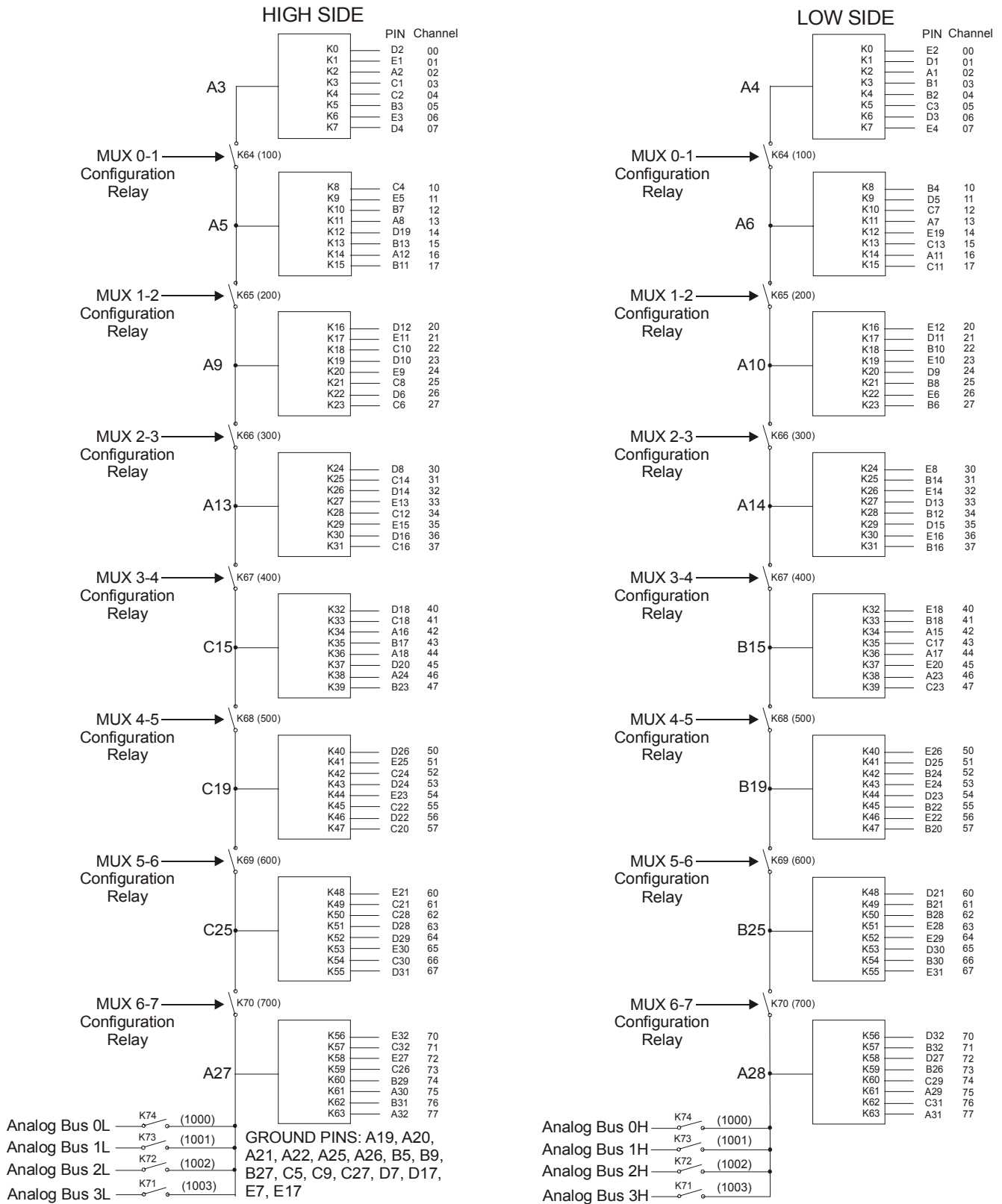

Figure 2-2, Block Diagram of 1260-138A

Configuration Relays

Model 1260-138A is configurable for a variety of applications. Referring back to **Figure 2-2**, there are seven configuration relays, numbered K64 through K70. **Figure 2-3** shows these relays from a different perspective, identifying them with their channel numbers (100, 200, etc.). **Figure 2-4** shows a detailed view of the components inside a multiplexer.

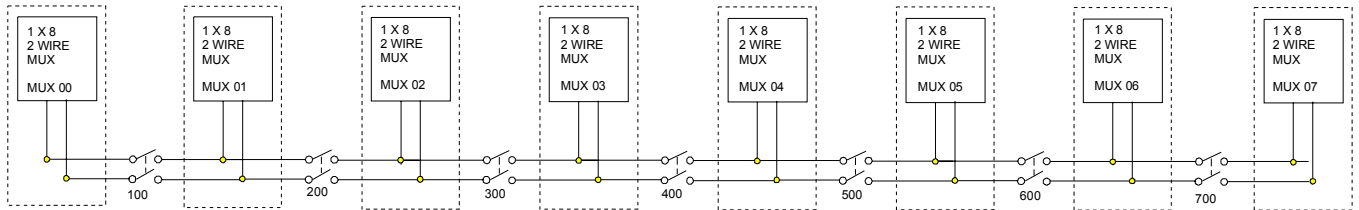

Figure 2-3, 1260-138A Module Configuration Block Diagram.

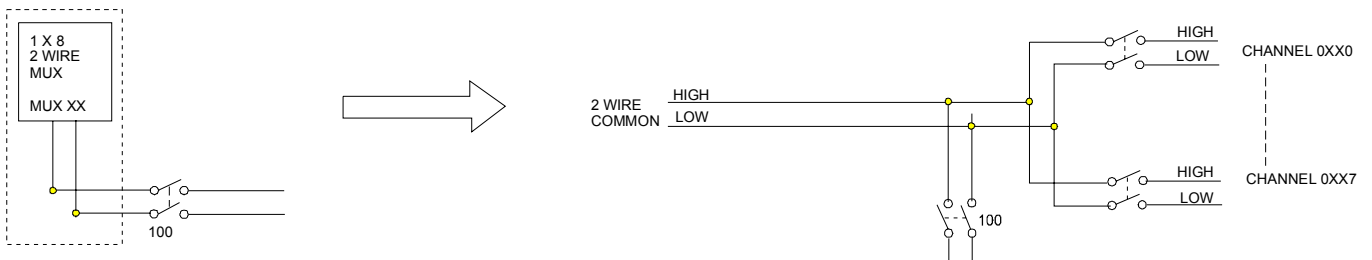

Figure 2-4, 1260-138A Multiplexer Configuration Block Diagram

Table 2-1 shows the command arguments (channel numbers) for connecting mux pairs together. For further details, refer to the section entitled “Configuring Larger Multiplexers” in Chapter 3.

Table 2-1, Command Arguments for Interconnecting the Muxes

MUX Interconnection	Command Argument (Channel)	Interconnect Relay	Pin	
			High	Low
0-1	(100)	K64	A5	A6
1-2	(200)	K65	A9	A10
2-3	(300)	K66	A13	A14
3-4	(400)	K67	C15	B15
4-5	(500)	K68	C19	B19
5-6	(600)	K69	C25	B25
6-7	(700)	K70	A27	A28

Analog Bus Relays

For even greater flexibility, Model 1260-138A takes full advantage of the analog bus found in the 1260-100/101 Adapt-a-Switch Carrier and 1256 Switching System. Four analog bus relays (K71 through K74 in the lower left-hand corner of **Figure 2-2**) connect the output of multiplexer 7 to any of the four analog bus pairs. For details on using the analog bus, refer to the section "Creating Very Large Multiplexers with the Analog Bus" in Chapter 3.

Table 2-2 shows the command arguments (channel numbers) for connecting the mux 7 output to the analog bus.

Table 2-2, Command Arguments for Connecting to the Analog Bus

Analog Bus	Command Argument (Channel)	Interconnect Relay	Pin	
			High	Low
0	(1000)	K74	A27	A28
1	(1001)	K73	A27	A28
2	(1002)	K72	A27	A28
3	(1003)	K71	A27	A28

Connector Pin Assignments

Table 2-3 provides the pin assignments for the front panel connector.

Table 2-3, 1260-138A Front-Panel Connections for J200

Mux	Channel	Pin	
		High	Low
0	Mux 0 Common	A3	A4
0	0	D2	E2
0	1	E1	D1
0	2	A2	A1
0	3	C1	B1
0	4	C2	B2
0	5	B3	C3
0	6	E3	D3
0	7	D4	E4
1	Mux 1 Common	A5	A6
1	10	C4	B4
1	11	E5	D5

Mux	Channel	Pin	
		High	Low
1	12	B7	C7
1	13	A8	A7
1	14	D19	E19
1	15	B13	C13
1	16	A12	A11
1	17	B11	C11
2	Mux 2 Common	A9	A10
2	20	D12	E12
2	21	E11	D11
2	22	C10	B10
2	23	D10	E10
2	24	E9	D9
2	25	C8	B8
2	26	D6	E6
2	27	C6	B6
3	Mux 3 Common	A13	A14
3	30	D8	E8
3	31	C14	B14
3	32	D14	E14
3	32	E13	D13
3	34	C12	B12
3	35	E15	D15
3	36	D16	E16
3	37	C16	B16
4	Mux 4 Common	C15	B15
4	40	D18	E18
4	41	C18	B18
4	42	A16	A15
4	43	B17	C17
4	44	A18	A17
4	45	D20	E20
4	46	A24	A23
4	47	B23	C23
5	Mux 5 Common	C19	B19
5	50	D26	E26
5	51	E25	D25
5	52	C24	B24
5	53	D24	E24
5	54	E23	D23
5	55	C22	B22

Mux	Channel	Pin	
		High	Low
5	56	D22	E22
5	57	C20	B20
6	Mux 6 Common	C25	B25
6	60	E21	D21
6	61	C21	B21
6	62	C28	B28
6	63	D28	E28
6	64	D29	E29
6	65	E30	D30
6	66	C30	B30
6	67	D31	E31
7	Mux 7 Common	A27	A28
7	70	E32	D32
7	71	C32	B32
7	72	E27	D27
7	73	C26	B26
7	74	B29	C29
7	75	A30	A29
7	76	B31	C31
7	77	A32	A31
---	Ground	A19	---
---	Ground	A20	---
---	Ground	A21	---
---	Ground	A22	---
---	Ground	A25	---
---	Ground	A26	---
---	Ground	B5	---
---	Ground	B9	---
---	Ground	B27	---
---	Ground	C5	---
---	Ground	C9	---
---	Ground	C27	---
---	Ground	D7	---
---	Ground	D17	---
---	Ground	E7	---
---	Ground	E17	---

Front Panel Connector

The 1260-138A has one front-panel connector, labeled J200. It is a 160-pin, modified DIN style connector, with 0.025" square posts as pins. It has one pin for each input and one for each output. See **Figure 2-5** for the physical pin arrangement. **Table 2-3** shows the mapping of channel numbers to connector pins. For information about mating connectors and accessories, see the "Mating Connectors" section at the end of this chapter.

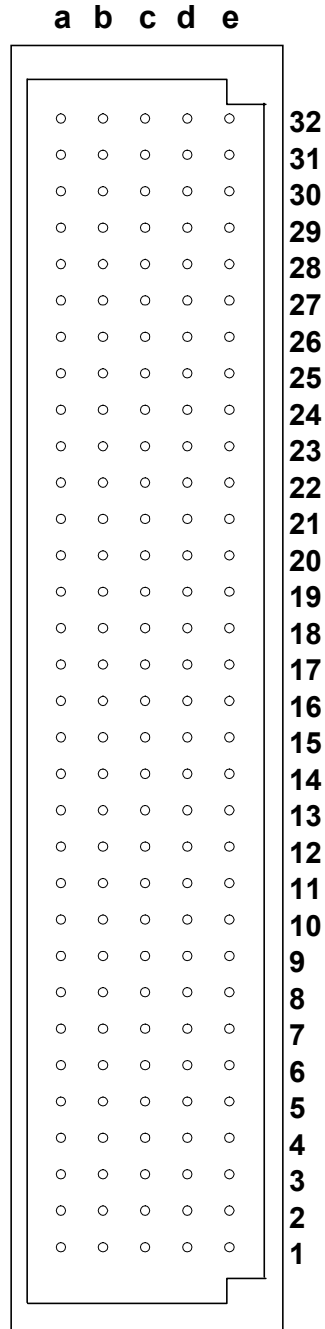

Figure 2-5, Front-Panel Connector Pin Numbering

Mating Connectors

The following mating connectors and accessories are available:

P/N 407408-001: 160-Pin Cable Assembly, 6 Ft., 24 AWG: This six-foot cable is constructed with 24 AWG stranded wire. One end has the mating connector for the 1260-138A. The other end is unterminated. Refer to **Table 2-1** for channel-to-pin mapping information.

P/N 407664: 160-Pin Connector Kit with Pins. This kit provides the mating connector for the 1260-138A, including housing, strain relief, and 170 crimp pins. After crimping, the pins snap into the connector housing, providing positive retention.

P/N 991033: ERNI Tool Kit. This kit includes the crimp tool and extractor.

P/N 990898: Insertion Hand Tool.

P/N 990899: Extraction Tool.

This page was left intentionally blank.

Chapter 3

MODULE OPERATION

Setting the Module Address

The Option-01T switch controller identifies each Adapt-a-Switch plug-in or conventional 1260-Series module by a *module address* that is unique to that module. The module address is a number from 1 through 12, inclusive.

The module address assigned to the 1260-138A is determined by the carrier slot into which the 1260-138A is inserted, and by the position of the logical address DIP switch on the carrier side panel. The logical address switch has two settings:

- 1-6: When the switch is set to this position, the module addresses of the plug-ins in the 1260-100 Carrier are from 1 through 6. The module with address 1 is in the left slot of the top row. The plug-ins are addressed in the following pattern:

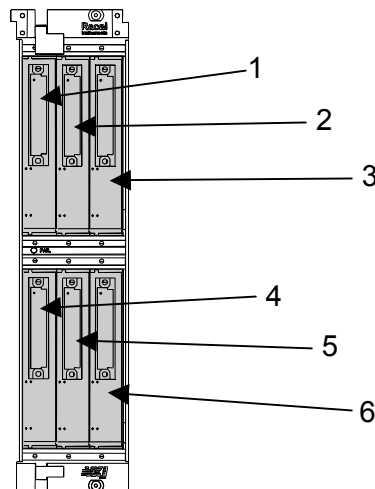

Figure 3-1, Front View – Module Addresses for 1 through 6

- 7-12: When the switch is set to this position, the module addresses of the plug-ins in the 1260-100 Carrier are from 7 through 12, in the following pattern:

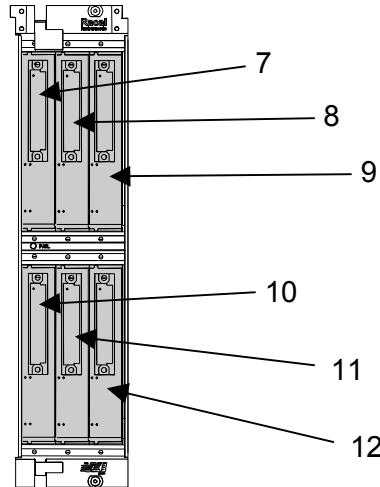

Figure 3-2 Front View – Module Addresses for 7 through 12

When setting module addresses for Adapt-a-Switch Carriers and conventional 1260-Series modules, be sure that no address is used by more than one plug-in or 1260-Series C-Size switching module.

For instructions on setting module addresses for a conventional 1260-Series module, see the label on the side panel of the module.

Operating Modes

The 1260-138A may be operated either in *message-based* mode or in *register-based* mode.

In *message-based* mode, the 1260-01T switch controller interprets commands sent by the slot 0 controller, and determines the appropriate data to send to the control registers of the 1260-138A module.

A conceptual view of the message-based mode of operation is shown in **Figure 3-3** below.

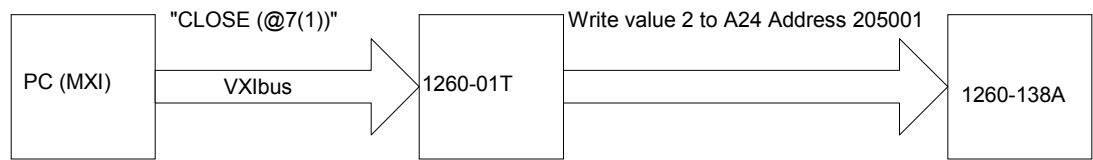

Figure 3-3, Message-Based Mode of Operation

In the *register-based* mode, the user writes directly to the control registers on the 1260-138A module. The 1260-01T command module does not monitor these operations, and does not keep track of the relay states on the 1260-138A module in this mode.

A conceptual view of the register-based mode is shown in **Figure 3-4** below.

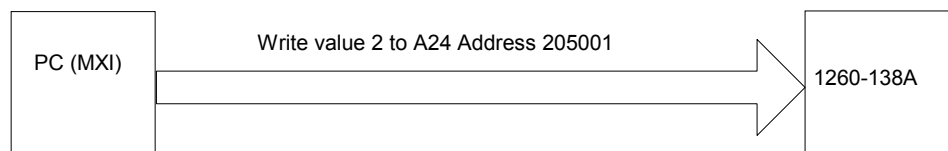

Figure 3-4, Register-Based Mode of Operation

Since the 1260-01T switch controller does not keep track of relay states during the register-based mode, it is advisable to use **either** the message-based or the register-based mode, and continue to use the same mode throughout the application program.

In general, the message-based mode of operation is easier to use with utility software such as the National Instruments VXI Interactive Control (VIC) program. The message-based mode allows the user to send ASCII text commands to the 1260-01T and to read replies from the 1260-01T. In addition, some features, such as the SCAN list, are available only in the message-based mode of operation.

The register-based mode provides faster control of relay channels. In this mode, relay operations are processed in less than 9 microseconds, not counting relay settling time or software overhead inherent in I/O libraries such as VISA. To determine the relay settling time, refer to Relay Settling Time in the Specifications section.

Consult the 1260-01T User's Manual for a comparison of the message-based and register-based modes of operation.

Operating In Message-Based Mode

Channel Descriptors For The 1260-138A

The standard 1260-01T commands are used to operate the 1260-138A module. These commands are described in the 1260-01T User's Manual.

Each 1260-01T relay command uses a *channel descriptor* to select the channel(s) of interest. The syntax for a channel descriptor is the same for all 1260 series modules. In general, the following syntax is used to select a single channel:

```
(@ <module address> ( <channel> ) )
```

Where:

- <module address> is the address of the 1260-138A module. This is a number in the range from 1 through 12, inclusive.
- <channel> is the 1260-138A channel to operate. They are numbers from 0-7, 10-17, 20-27, etc. See Figure 2-1 and Table 2-1.

Multiple individual channels may be specified using the following channel descriptor syntax:

```
@ <module address> ( <chan1> , <chan2>  
, . . . , <chanN> ) )
```

A range of channels may be specified using the following channel descriptor syntax:

```
@ <module address> ( <first channel> :  
<last channel> ) )
```

The following examples illustrate the use of the channel descriptors for the 1260-138A:

OPEN (@8 (0))	Open channel 0 on the 1260-138A that has module address 8.
CLOSE (@8 (0, 3))	Close channels 0 and 3 on the 1260-138A that has module address 8.
CLOSE (@2 (10:13))	Close channels 10 through 13 inclusive on the 1260-138A that has module address 2.

Reply To The MOD:LIST? Command

The 1260-01T returns a reply to the MOD:LIST? command. This reply is unique for each different 1260 series switch module. The syntax for the reply is:

<module address> : <module-specific identification string>

The <module-specific identification string> for the 1260-138A is:

1260-138 8 1X8 2A MUX

So, for a 1260-138A whose <module address> is set to 8, the reply to this query would be:

8: 1260-138 8 1X8 2A MUX

Operating The 1260-138A in Register-Based Mode

In register-based mode, the 1260-138A is operated by directly writing and reading control registers on the 1260-138A module. When a control register is written to, all channels controlled by that register are operated simultaneously. For the channel assignments for each control register, see **Table 3-1**.

The control registers are located in the VXIbus A24 Address Space. The A24 address for a control register depends on:

1. The A24 Address Offset assigned to the 1260-01T module by the Resource Manager program. The Resource Manager program is provided by the VXIbus slot-0 controller vendor. The A24 Address Offset is placed into the "Offset Register" of the 1260-01T by the Resource Manager.
2. The <module address> of the 1260-138A module. This is a value in the range from 1 and 12 inclusive.
3. The 1260-138A control register to be written to or read from. Each control register on the 1260-138A has a unique address.

The base A24 address for the 1260-138A module may be calculated by:

$$(A24 \text{ Offset of the 1260-01T}) + (1024 \times \text{Module Address of 1260-138A}).$$

The A24 address offset is usually expressed in hexadecimal. A typical value of 204000_{16} is used in the examples that follow.

A 1260-138A with a module address of 7 would have the base A24 address computed as follows:

$$\begin{aligned} \text{Base A24 Address of 1260-138A} &= 204000_{16} + (400_{16} \times 7_{10}) \\ &= 205C00_{16} \end{aligned}$$

The control registers for Adapt-a-Switch plug-ins and conventional 1260-Series modules are always on odd-numbered A24 addresses. The three control registers for the 1260-138A reside at the first three odd-numbered A24 addresses for the module:

$$(\text{Base A24 Address of 1260-138A}) + 1 = \text{Control Register 0}$$

$$(\text{Base A24 Address of 1260-138A}) + 3 = \text{Control Register 1}$$

$$(\text{Base A24 Address of 1260-138A}) + 5 = \text{Control Register 2}$$

So, for our example, the first three control registers are located at:

205C01	Control Register 0, controls channels 64, 65, 66, 67, 70, 72, 73, 74
205C03	Control Register 1, controls channels 76, 62, 63, 1000, 700, 71, 75, 77
205C05	Control Register 2, controls channels 57, 600, 60, 61, 51, 50, 500, 47.

Table 3-1 shows the channel assignments for each control register.

Table 3-1, Control Register Channel Assignments

Control Register	Channels							
	Bit 7 (MSB)	Bit 6	Bit 5	Bit 4	Bit 3	Bit 2	Bit 1	Bit 0 (LSB)
0	64	65	66	67	70	72	73	74
1	76	62	63	1000	700	71	75	77
2	57	600	60	61	51	50	500	47
3	46	41	55	56	54	53	52	1001
4	36	37	400	40	42	43	44	45
5	16	15	1002	31	32	33	34	35
6	27	26	25	22	21	20	200	17
7	3	4	5	14	13	1003	30	300
8	2	7	23	24	100	10	11	12
9	6	Unused	Unused	Unused	Unused	Unused	0	1

Setting a control bit to 1 closes the corresponding channel, and clearing the bit to zero opens the corresponding channel. Thus, if you write the value 1000 0101 binary = 133 decimal = 85 hexadecimal to Control Register 0, channels 64, 72, and 74 will close, while channels 65, 66, 67, 70, and 73 will open.

The present control register value may be read back by reading an 8-bit value from the control register address. **The value is inverted.** In other words, the eight-bit value read back is the one's complement of the value written.

If you want to change the state of a single relay without affecting the present state of the other relays controlled by the control register, you must:

1. Read the control register
2. Invert the bits (perform a one's complement on the register data)
3. Perform a bit-wise AND operation, leaving all but the specific control register bit for the relay to change
4. **To open:** continue to step 5. **To close:** OR in the bit for the relay to close.
5. Write the modified value back to the control register.

For example, to close channel 63:

1. Read Control Register 1 (this register controls 76, 62, 63, 1000,700,71, 75, and 77 with channel 77 represented by the LSB)
2. Invert the bits in the value read in step 1
3. AND with 1101 1111 binary (the zero is in the position corresponding to channel 63)
4. OR with 0010 0000 binary
5. Write the value to Control Register 1

The VISA I/O library may be used to control the module. The VISA function `viOut8()` is used to write a single 8-bit byte to a control register, while `viIn8()` is used to read a single 8-bit byte from the control register. The following code example shows the use of `viOut8()` to update the 1260-138A module.

Configuring Larger Multiplexers

The 1260-138A is normally configured as eight 1x8 multiplexers. However, the plug-in contains seven special configuration relays that interconnect two or more multiplexers to form larger multiplexers. **Figure 2-1** shows these relays, identified as K64 through K70. **Table 3-1** provides the control register access information for these relays. Each configuration relay connects the commons of two multiplexers together.

Configuration may be done “on-the-fly” if desired.

As a configuration example, suppose you require two 1x16 multiplexes and one 2x24 multiplexer. You may form these multiplexers from a 1260-138A by configuring it as follows:

1. Combine muxes 0 and 1 to form a 1x16 multiplexer. To do this, we must close the relay shown as “Mux 0-1” in **Figure 2-1**. Referring to **Table 3-1**, we see that bit 3 of control register 8 controls this configuration relay. To combine the multiplexers, write to the register to set this bit (leave the other bits unchanged).
2. Combine multiplexers 2, 3, and 4 to form a 1x24 multiplexer. To do this, close the “Mux 2-3” and “Mux 3-4” configuration relays (K66 and K67 in **Figure 2-1**). From **Table 3-1** we see that the “Mux 2-3” relay is controlled by bit 0 of control register 1. Also, bit 5 of control register 4 controls the “Mux 3-4” relay. Set both of these bits (without changing any other bits).

Creating Very Large Multiplexers With the Analog Bus

The 1260-138A has access to the analog bus of the 1260-100 Carrier. The analog bus can connect multiplexer 0 of one 1260-138A to multiplexer 0 of another 1260-138A, providing endless possibilities for creating large multiplexers from two or more plug-ins.

The analog bus consists of four two-wire paths, numbered as Abus 0 through Abus 3. These paths are accessible from any Adapt-a-Switch Carrier slot. To link multiplexer 0 of one 1260-138A to multiplexer 0 of another 1260-138A, we must connect them both to the same analog bus path.

For example, suppose you wish to create a 1x128 multiplexer. This requires two 1260-138A plug-ins. To configure them as a single 1x128 multiplexer, proceed as follows:

1. Configure the first 1260-138A as a 1x64 multiplexer. To do this, close the following configuration relays (shown in **Figure 2-1**):

Mux 1-2
Mux 2-3
Mux 3-4
Mux 4-5
Mux 5-6
Mux 6-7
Mux 7-8

Table 3-1 indicates the registers and bit positions used to control these relays. Setting a bit to 1 closes the relay.

2. Configure the second 1260-138A as a 1x64 multiplexer. Close the following configuration relays (shown in **Figure 2-1**):

Mux 1-2
Mux 2-3
Mux 3-4
Mux 4-5
Mux 5-6
Mux 6-7
Mux 7-8

3. Next, we connect both of these 1x64 multiplexers to the same analog bus path, forming a single 1x128 multiplexer. Close the "Abus 0" relay on the first plug-in. Referring to **Table 3-2**, we see that this relay is controlled by bit 4 of control register 1. Set the bit to 1 to close the relay.

4. In the same manner, close the “Abus 0” relay on the second plug-in.

This connects the commons of both 1260-138A plug-ins to Abus 0, thereby connecting them together. This completes the formation of the 1x128 multiplexer.

Note that, in the above example, paths Abus 1, Abus 2, and Abus 3 are unused. If desired, you may use these independent paths to connect additional groups of plug-ins together.

1260-138A Example Code

```
#include <visa.h>

/* This example shows a 1260-01T at logical address 16 and a VXI/MXI */
/* interface */
#define RI1260_01_DESC      "VXI::16"

/* For a GPIB-VXI interface, and a logical address of 77 */
/* the descriptor would be: "GPIB-VXI::77" */

/* this example shows a 1260-138A with module address 7 */
#define MOD_ADDR_138  7

void example_operate_1260_138(void)
{
    ViUInt8 creg_val;
    ViBusAddress creg0_addr;
    ViBusAddress creg1_addr;
    ViBusAddress creg2_addr;
    ViSession hdl1260;    /* VISA handle to the 1260-01T */
    ViSession hdlRM;     /* VISA handle to the resource manager */
    ViStatus error;      /* VISA error code */

    /* open the resource manager */
    /* this must be done once in application program */
    error = viOpenDefaultRM (&hdlRM);

    if (error < 0) {
        /* error handling code goes here */
    }

    /* get a handle for the 1260-01T */
    error = viOpen (hdlRM, RI1260_01_DESC, VI_NULL,VI_NULL, &hdl1260);
    if (error < 0) {
        /* error handling code goes here */
    }

    /* form the offset for control register 0 */
    /* note that the base A24 Address for the 1260-01T */
    /* is already accounted for by VISA calls viIn8() and */

```

```
/* viOut8() */

    /* module address shifted 10 places = module address x 1024 */
    creg0_addr = (MOD_ADDR_138 << 10) + 1;
    creg1_addr = creg0_addr + 2;
    creg2_addr = creg1_addr + 2;

/* close channel 63 without affecting the state of */
/* channels 76, 62, 1000, 700, 71, 75, and 77 */
error = viIn8 (hdl1260, VI_A24_SPACE, creg1_addr, &creg_val);
if (error < 0) {
    /* error handling code goes here */
}

/* invert the bits to get the present control register value */
creg_val = ~creg_val;

/* AND to leave every channel except 63 unchanged */
creg_val &= ~ (0x20);

/* OR in the bit to close channel 63 */
creg_val |= 0x20;

/* write the updated control register value */
error = viOut8 (hdl1260, VI_A24_SPACE, creg1_addr, creg_val);
if (error < 0) {
    /* error handling code goes here */
}

/* open channel 47 without affecting channels 57, 600, 60, 51, 59, 500 */
error = viIn8 (hdl1260, VI_A24_SPACE, creg2_addr, &creg_val);
if (error < 0) {
    /* error handling code goes here */
}

/* invert the bits to get the present control register value */
creg_val = ~creg_val;

/* AND to leave every channel except 47 unchanged */
/* leave bit 0 clear to open channel 47 */
creg_val &= ~ (0x01);

/* write the updated control register value */
error = viOut8 (hdl1260, VI_A24_SPACE, creg2_addr, creg_val);
if (error < 0) {
    /* error handling code goes here */
}
}
```

```
/* close the VISA session */
error = viClose( hdl1260 );
if (error < 0) {
    /* error handling code goes here */
}
}
```

This page was left intentionally blank.

Chapter 4

OPTIONAL ASSEMBLIES

407664	Connector Kit, 160 Pin Crimp.....	4-3
407408-001	Cable Assy, 160 Pin, 6 ft, 24AWG.....	4-4

This page was left intentionally blank.

1260-138A User Manual

RACAL INSTRUMENTS, INC.

Assembly 407664

Connector kit, 160 Pin, Crimp

Rev Date 7/30/98 Revision A

#	Component	Description	U/M	Qty Reqd.	REF
1	602258-116	CON-CAB-RCP160C,100S	-E EA	1.000	
2	602258-900	TRMCRP-SNP-U-F26-20G	-E EA	170.000	

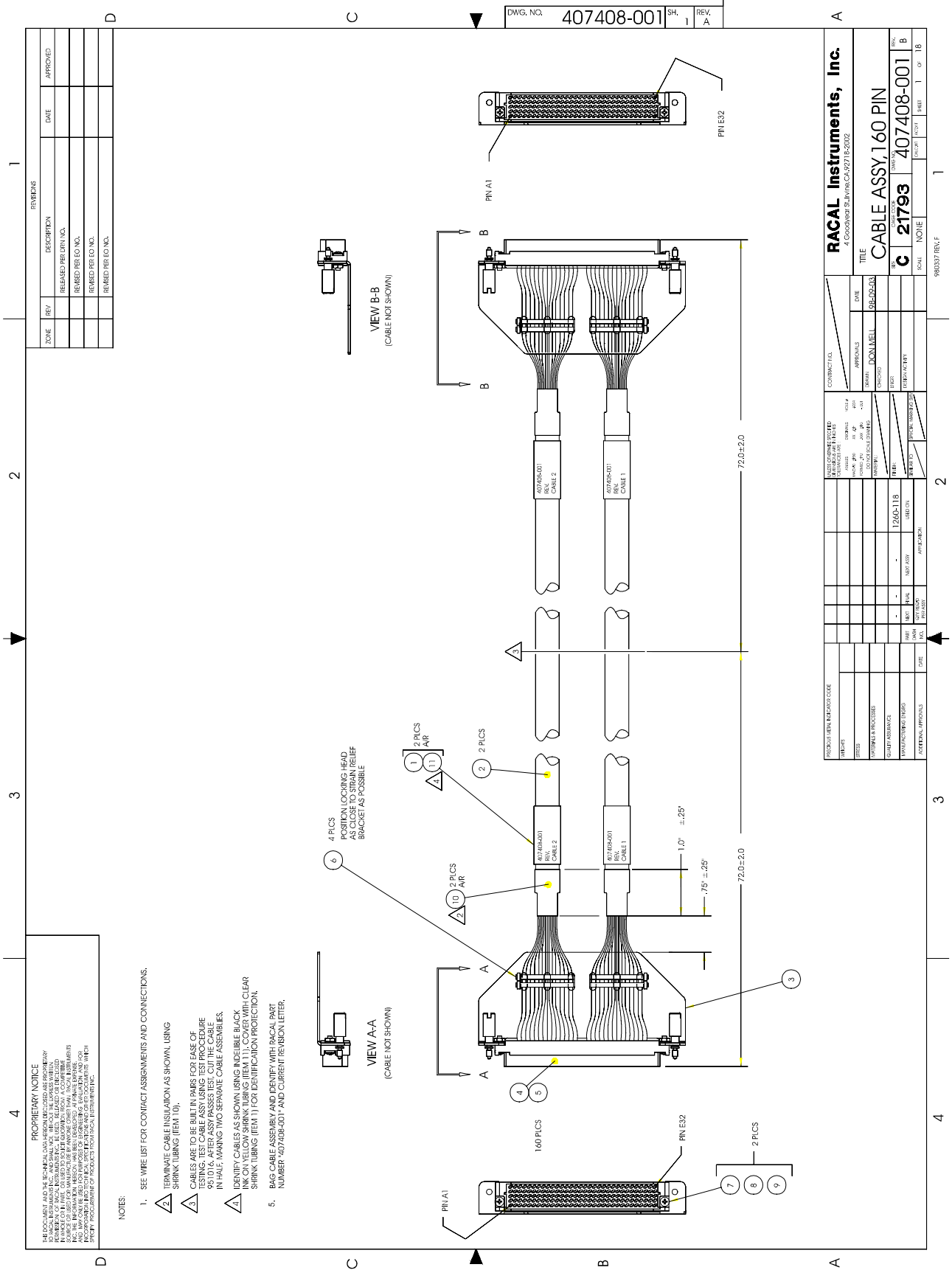

PROPRIETARY NOTICE
 THIS DOCUMENT AND THE TECHNICAL DATA CONTAINED HEREIN ARE THE PROPERTY OF RACAL INSTRUMENTS, INC. AND SHALL BE USED ONLY FOR THE PURPOSES SPECIFIED IN THE DRAWING. IT IS TO BE KEPT IN CONFIDENCE AND NOT TO BE REPRODUCED OR TRANSMITTED IN ANY FORM OR BY ANY MEANS, ELECTRONIC OR MECHANICAL, INCLUDING PHOTOCOPYING, RECORDING, OR BY ANY INFORMATION STORAGE AND RETRIEVAL SYSTEM, WITHOUT THE WRITTEN PERMISSION OF RACAL INSTRUMENTS, INC. ANY UNAUTHORIZED REPRODUCTION OR TRANSMISSION OF THIS DOCUMENT OR THE CONTENTS HEREIN IS STRICTLY PROHIBITED AND IS SUBJECT TO PROSECUTION.

- NOTES:**
- SEE WIRE LIST FOR CONTACT ASSIGNMENTS AND CONNECTIONS.
 - TERMINATE CABLE INSULATION AS SHOWN, USING SHRINK TUBING (ITEM 10).
 - CABLES ARE TO BE BUILT IN PAIRS FOR EASE OF TESTING. TEST CABLE ASSEMBLY TEST PROCEDURE IS TO BE PERFORMED IN PAIRS. MAKE SURE TO IDENTIFY CABLES IN HALF, MAKING TWO SEPARATE CABLE ASSEMBLIES.
 - IDENTIFY CABLES AS SHOWN, USING INDELIBLE BLACK INK. INK LABELS MUST BE CLEARLY IDENTIFIABLE WITH CLEAR SHRINK TUBING (ITEM 11) FOR IDENTIFICATION PROTECTION.
 - BAG CABLE ASSEMBLY AND IDENTIFY WITH RACAL PART NUMBER 407455601 AND CURRENT REVISION LETTER.

ZONE	REV	DESCRIPTION	DATE	APPROVED
		RELEASED PER DYN NO.		
		REMOVED PER E.O. NO.		
		REMOVED PER E.O. NO.		
		REMOVED PER E.O. NO.		

CONTRACT NO. 407408-001		TITLE CABLE ASSY 160 PIN	
APPROVALS DRAWN: DOONMELL CHECKED:	DATE 08-20-03	PART NO. 407408-001	REV. B
QUANTITY 1260-118	PART NO. 1260-118	PART NO. 407408-001	REV. B
MANUFACTURING ENG. DATE 08/20/03	APPR. DATE 08/20/03	PART NO. 407408-001	REV. B
SPECIAL APPROVALS	DATE 08/20/03	PART NO. 407408-001	REV. B

1260-138A User Manual

RACAL INSTRUMENTS INC.

Assembly 407408-001

CABLE ASSY,160 PIN

Rev Date 2/19/99 Revision B

#	Component	Description	U/M	Qty Reqd	Ref
1	500104	TBGSRK-POF. 750ID-CLEAR	FT	.00001	
2	500319	CAMT-USH-80C24G-1STR	FT	14.00000	
3	456673	BRKT,STRAIN RELIEF, 160 PIN	EA	1.00000	
4	602258-116	CON-CAB-RCP160C.100S	EA	1.00000	
5	602258-900	TRMCRP-SNP-U-F26-20G	EA	160.00000	
6	610777	TIE-CA-LKG-.062-. 750	EA	4.00000	
7	616303	S1MPPAN-M2. 5x0. 45X08	EA	2.00000	
8	617041	NT1IIBXM2 .5-0. 50-STL	EA	2.00000	
9	617127	W1S004. 202D. 020T.115	EA	2.00000	
10	M23053/5-109-4	TBGSRK-POF. 750ID-YELLOW	FT	.00001	
11	M23053/5-109-0	TBGSRK-POF. 750ID-BLACK	FT	.00001	

ENGINEERING WIRE LIST

FROM	TO	CONDUCTOR TYPE, GAUGE, COLOR	PART NO.	WIRE LENGTH	REFERENCE
P31-A P32-A	P31-A P32-A	CABLE 1 WHT/BLK/ORG/VIO CABLE 1 WHT/BLK/YEL/GRY			
P31-B P32-B	P31-B P32-B	CABLE 1 WHT/BLK/ORG/GRY CABLE 1 WHT/BLK/GRN/BLU			
P31-D P32-D	P31-D P32-D	CABLE 1 WHT/BLK/YEL/BLU CABLE 1 WHT/BLK/GRN/GRY			
P31-E P32-E	P31-E P32-E	CABLE 1 WHT/BLK/YEL/VIO CABLE 1 WHT/BLK/BLU/VIO			
P29-A P30-A	P29-A P30-A	CABLE 1 WHT/BLK/BRN/VIO~ CABLE 1 WHT/BLK/RED/VIO			
P29-B P30-B	P29-B P30-B	CABLE 1 WHT/BLK/BRN/GRY CABLE 1 WHT/BLK/RED/GRY			
P29-D P30-D	P29-D P30-D	CABLE 1 WHT/BLK/RED/GRN CABLE 1 WHT/BLK/ORG/GRN			
P29-E P30-E	P29-E P30-E	CABLE 1 WHT/BLK/RED/BLU CABLE 1 WHT/BLK/ORG/BLU			
P31-C P32-C	P31-C P32-C	CABLE 1 WHT/BLK/YEL/GRN CABLE 1 WHT/BLK/GRN/VIO			
P27-C P28-C	P27-C P28-C	CABLE 1 WHT/BLU/VIO CABLE 1 WHT/BLK/BRN/YEL			
P30-C P29-C	P30-C P29-C	CABLE 1 WHT/BLK/ORG/YEL CABLE 1 WHT/BLK/RED/YEL			
RACAL Instruments, Inc., 4 Goodyear St., Irvine, CA 92618					
DOCUMENT TITLE		SIZE	CODE NO.	DOCUMENT NO	REV
CABLE ASSY,160 PIN		A	21793	407408-001	. A
DRN			SHEET 2 of 17		

ENGINEERING WIRE LIST

FROM	TO	CONDUCTOR TYPE, GAUGE, COLOR	PART NO.	WIRE LENGTH	REFERENCE
P27-A P28-A	P27-A P28-A	CABLE 1 WHT/GRN/VIO CABLE 1 WHT/BLK/BRN/RED			
P27-B P28-B	P27-B P28-B	CABLE 1 WRT/GRN/GRY CABLE 1 WHT/BLK/BRN/ORN			
P27-D P28-D	P27-D P28-D	CABLE 1 WHT/BLU/GRY CABLE 1 WHT/BLK/BRN/GRN			
P27-E P28-E	P27-E P28-E	CABLE 1 WHT/VIO/GRY CABLE 1 WHT/BLK/BRN/BLU			
P25-A P26-A	P25-A P26-A	CABLE 1 WHT/ORN/YEL CABLE 1 WHT/YEL/GRN			
P25-B P26-B	P25-B P26-B	CABLE 1 WHT/ORN/GRN CABLE 1 WHT/YEL/BLU			
P25-D P26-D	P25-D P26-D	CABLE 1 WHT/ORN/VIO CABLE 1 WHT/YEL/GRY			
P25-E P26-E	P25-E P26-E	CABLE 1 WHT/ORN/GRY CABLE 1 WHT/GRN/BLU			
P25-C P26-C	P25-C P26-C	CABLE 1 WHT/ORN/BLU CABLE 1 WHT/YEL/VIO			
RACAL Instruments, Inc., 4 Goodyear St., Irvine, CA 92618					
DOCUMENT TITLE		SIZE	CODE NO.	DOCUMENT NO	REV
CABLE ASSY,160 PIN		A	21793	407408-001	. A
DRN			SHEET 3 of 17		

ENGINEERING WIRE LIST

FROM	TO	CONDUCTOR TYPE, GAUGE, COLOR	PART NO.	WIRE LENGTH	REFERENCE
P23-A P24-A	P23-A P24-A	CABLE 1 WHT/BRN/GRN CABLE 1 WRT/RED/YEL			
P23-B P24-B	P23-B P24-B	CABLE 1 WHT/BRN/BLU CABLE 1 WHT/RED/GRN			
P23-D P24-D	P23-D P24-D	CABLE 1 WHT/BRN/GRY CABLE 1 WHT/RED/VIO			
P23-E P24-E	P23-E P24-E	CABLE 1 WHT/RED/ORN CABLE 1 WHT/RED/GRY			
P21-A P22-A	P21-A P22-A	CABLE 1 WHT/BLK/RED CABLE 1 WHT/BLK/VIO			
P21-B P22-B	P21-B P22-B	CABLE 1 WHT/BLK/ORN CABLE 1 WHT/BLK/GRY			
P21-D P22-D	P21-D P22-D	CABLE 1 WHT/BLK/GRN CABLE 1 WHT/BRN/ORN			
P21-E P22-E	P21-E P22-E	CABLE 1 WHT/BLK/BLU CABLE 1 WHT/BRN/YEL			
P23-C P24-C	P23-C P24-C	CABLE 1 WHT/BRN/VIO CABLE 1 WHT/RED/BLU			
P19-C	P19-C	CABLE 1 WHT/RED			
P20-C	P20-C	CABLE 1 WHT/VIO			
P22-C	P22-C	CABLE 1 WHT/BRN/RED			
P21-C	P21-C	CABLE 1 WHT/BLK/YEL			
RACAL Instruments, Inc., 4 Goodyear St., Irvine, CA 92618					
DOCUMENT TITLE		SIZE	CODE NO.	DOCUMENT NO	REV
CABLE ASSY,160 PIN		A	21793	407408-001	. A
DRN			SHEET 4 of 17		

ENGINEERING WIRE LIST

FROM	TO	CONDUCTOR TYPE, GAUGE, COLOR	PART NO.	WIRE LENGTH	REFERENCE
P19-A P20-A	P19-A P20-A	CABLE 1 WHT/BLK CABLE 1 WHT/GRN			
P19-B P20-B	P19-B P20-B	CABLE 1 WHT/BRN CABLE 1 WHT/BLU			
P19-D P20-D	P19-D P20-D	CABLE 1 WHT/ORN CABLE 1 WHT/GRY			
P19-E P20-E	P19-E P20-E	CABLE 1 WHT/YEL CABLE 1 WHT/BLK/BRN			
P17-A P18-A	P17-A P18-A	CABLE 1 BLK CABLE 1 GRN			
P17-B P18-B	P17-B P18-B	CABLE 1 BRN CABLE 1 BLU			
P17-D P18-D	P17-D P18-D	CABLE 1 ORN CABLE 1 GRY			
P17-E P18-E	P17-E P18-E	CABLE 1 YEL CABLE 1 WHT			
P17-C	P17-C	CABLE 1 RED			
P18-C	P18-C	CABLE 1 VIO			

RACAL Instruments, Inc., 4 Goodyear St., Irvine, CA 92618

DOCUMENT TITLE	SIZE	CODE NO.	DOCUMENT NO	REV
CABLE ASSY,160 PIN	A	21793	407408-001	. A
	DRN		SHEET 5 of 17	

ENGINEERING WIRE LIST

FROM	TO	CONDUCTOR TYPE, GAUGE, COLOR	PART NO.	WIRE LENGTH	REFERENCE
P15-A P16-A	P15-A P16-A	CABLE 1 WHT/BLK/ORN/VIO CABLE 1 WRT/BLK/YEL/GRY			
P15-B P16-B	P15-B P16-B	CABLE 1 WHT/BLK/ORN/GRY CABLE 1 WHT/BLK/GRN/BLU			
P15-D P16-D	P15-D P16-D	CABLE 1 WHT/BLK/YEL/BLU CABLE 1 WHT/BLK/GRN/GRY			
P15-E P16-E	P15-E P16-E	CABLE 1 WHT/BLK/YEL/VIO CABLE 1 WHT/BLK/BLU/VIO			
P13-A P14-A	P13-A P14-A	CABLE 1 WHT/BLK/BRN/VIO CABLE 1 WHT/BLK/RED/VIO			
P13-B P14-B	P13-B P14-B	CABLE 1 WHT/BLK/BRN/GRY CABLE 1 WHT/BLK/RED/GRY			
P13-D P14-D	P13-D P14-D	CABLE 1 WHT/BLK/RED/GRN CABLE 1 WHT/BLK/ORN/GRN			
P13-E P14-E	P13-E P14-E	CABLE 1 WHT/BLK/RED/BLU CABLE 1 WHT/BLK/ORN/BLU			
P15-C P16-C	P15-C P16-C	CABLE 1 WHT/BLK/YEL/GRN CABLE 1 WHT/BLK/GRN/VIO			
P11-C P12-C	P11-C P12-C	CABLE 1 WHT/BLU/VIO CABLE 1 WHT/BLK/BRN/YEL			
P14-C	P14-C	CABLE 1 WHT/BLK/ORN/YEL			
P13-C	P13-C	CABLE 1 WHT/BLK/RED/YEL			
RACAL Instruments, Inc., 4 Goodyear St., Irvine, CA 92618					
DOCUMENT TITLE		SIZE	CODE NO.	DOCUMENT NO	REV
CABLE ASSY,160 PIN		A	21793	407408-001	. A
DRN			SHEET 6 of 17		

ENGINEERING WIRE LIST

FROM	TO	CONDUCTOR TYPE, GAUGE, COLOR	PART NO.	WIRE LENGTH	REFERENCE
P11-A P12-A	P11-A P12-A	CABLE 1 WHT/GRN/VIO CABLE 1 WHT/BLK/BRN~RED			
P11-B P12-B	P11-B P12-B	CABLE 1 WHT/GRN/GRY CABLE 1 WHT/BLK/BRNIORN			
P11-D P12-D	P11-D P12-D	CABLE 1 WHT/BLU/GRY CABLE 1 WHT/BLK/BRNIGRN			
P11-E P12-E	P11-E P12-E	CABLE 1 WHT/VIO/GRY CABLE 1 WHT/BLK/BRNJBLU			
P9-A P10-A	P9-A P10-A	CABLE 1 WHT/ORN/YEL CABLE 1 WHT/YEL/GRN			
P9-B P10-B	P9-B P10-B	CABLE 1 WHT/ORN/GRN CABLE 1 WHT/YEL/BLU			
P9-D P10-D	P9-D P10-D	CABLE 1 WHT/ORN/VIO CABLE 1 WHT/YEL/GRY			
P9-E P10-E	P9-E P10-E	CABLE 1 WHT/ORN/GRY CABLE 1 WHT/GRN/BLU			
P9-C	P9-C	CABLE 1 WHT/ORN/BLU			
P10-C	P10-C	CABLE 1 WHT/YEL/VIO			
RACAL Instruments, Inc., 4 Goodyear St., Irvine, CA 92618					
DOCUMENT TITLE		SIZE	CODE NO.	DOCUMENT NO	REV
CABLE ASSY,160 PIN		A	21793	407408-001	. A
DRN				SHEET 7 of 17	

ENGINEERING WIRE LIST

FROM	TO	CONDUCTOR TYPE, GAUGE, COLOR	PART NO.	WIRE LENGTH	REFERENCE
P7-A P8-A	P7-A P8-A	CABLE 1 WHT/BRN/GRN CABLE 1 WHT/RED/YEL			
P7-B P8-B	P7-B P8-B	CABLE 1 WHT/BRN/BLU CABLE 1 WHT/RED/GRN			
P7-D P8-D	P7-D P8-D	CABLE 1 WHT/BRN/GRY CABLE 1 WHT/RED/VIO			
P7-E P8-E	P7-E P8-E	CABLE 1 WHT/RED/ORN CABLE 1 WHT/RED/GRY			
P5-A P6-A	P5-A P6-A	CABLE 1 WHT/BLK/RED CABLE 1 WHT/BLK/VIO			
P5-B P6-B	P5-B P6-B	CABLE 1 WHT/BLK/ORN CABLE 1 WHT/BLK/GRY			
P5-D P6-D	P5-D P6-D	CABLE 1 WHT/BLK/GRN CABLE 1 WHT/BRN/ORN			
P5-E P6-E	P5-E P6-E	CABLE 1 WHT/BLK/BLU CABLE 1 WHT/BRN/YEL			
P7-C P8-C	P7-C P8-C	CABLE 1 WHT/BRN/VIO CABLE 1 WHT/RED/BLU			
P3-C P4-C	P3-C P4-C	CABLE 1 WHT/RED CABLE 1 WHT/VIO			
P6-C P5-C	P6-C P5-C	CABLE 1 WHT/BRN/RED CABLE 1 WHT/BLK/YEL			
RACAL Instruments, Inc., 4 Goodyear St., Irvine, CA 92618					
DOCUMENT TITLE		SIZE	CODE NO.	DOCUMENT NO	REV
CABLE ASSY,160 PIN		A	21793	407408-001	. A
DRN			SHEET 8 of 17		

ENGINEERING WIRE LIST

FROM	TO	CONDUCTOR TYPE, GAUGE, COLOR	PART NO.	WIRE LENGTH	REFERENCE
P3-A P4-A	P3-A P4-A	CABLE 1 WHT/BLK CABLE 1 WHT/GRN			
P3-B P4-B	P3-B P4-B	CABLE 1 WHT/BRN CABLE 1 WHT/BLU			
P3-D P4-D	P3-D P4-D	CABLE 1 WHT/ORN CABLE 1 WHT/GRY			
P3-E P4-E	P3-E P4-E	CABLE 1 WHT/YEL CABLE 1 WHT/BLK/BRN			
P1-A P2-A	P1-A P2-A	CABLE 1 BLK CABLE 1 GRN			
P1-B P2-B	P1-B P2-B	CABLE 1 BRN CABLE 1 BLU			
P1-D P2-D	P1-D P2-D	CABLE 1 ORN CABLE 1 GRY			
P1-E P2-E	P1-E P2-E	CABLE 1 YEL CABLE 1 WHT			
P1-C P2-C	P1-C P2-C	CABLE 1 RED CABLE 1 VIO			
RACAL Instruments, Inc., 4 Goodyear St., Irvine, CA 92618					
DOCUMENT TITLE		SIZE	CODE NO.	DOCUMENT NO	REV
CABLE ASSY,160 PIN		A	21793	407408-001	. A
DRN			SHEET 9 of 17		

ENGINEERING WIRE LIST

FROM	TO	CONDUCTOR TYPE, GAUGE, COLOR	PART NO.	WIRE LENGTH	REFERENCE
P31-A P32-A	P31-A P32-A	CABLE 2 WHT/BLK/ORN/VIO CABLE 2 WHT/BLK/YEL/GRY			
P31-B P32-B	P31-B P32-B	CABLE 2 WHT/BLK/ORN/GRY CABLE 2 WHT/BLK/GRN/BLU			
P31-D P32-D	P31-D P32-D	CABLE 2 WHT/BLK/YEL/BLU CABLE 2 WHT/BLK/GRN/GRY			
P31-E P32-E	P31-E P32-E	CABLE 2 WHT/BLK/YEL/VIO CABLE 2 WHT/BLK/BLU/VIO			
P29-A P30-A	P29-A P30-A	CABLE 2 WHT/BLK/BRN/VIO CABLE 2 WHT/BLK/RED/VIO			
P29-B P30-B	P29-B P30-B	CABLE 2 WHT/BLK/BRN/GRY CABLE 2 WHT/BLK/RED/GRY			
P29-D P30-D	P29-D P30-D	CABLE 2 WHT/BLK/RED/GRN CABLE 2 WHT/BLK/ORN/GRN			
P29-E P30-E	P29-E P30-E	CABLE 2 WHT/BLK/RED/BLU CABLE 2 WHT/BLK/ORN/BLU			
P31-C P32-C	P31-C P32-C	CABLE 2 WHT/BLK/YEL/GRN CABLE 2 WHT/BLK/GRN/VIO			
P27-C P28-C	P27-C P28-C	CABLE 2 WHT/BLU/VIO CABLE 2 WHT/BLK/BRN/YEL			
P30-C P29-C	P30-C P29-C	CABLE 2 WHT/BLK/ORN/YEL CABLE 2 WHT/BLK/RED/YEL			
RACAL Instruments, Inc., 4 Goodyear St., Irvine, CA 92618					
DOCUMENT TITLE		SIZE	CODE NO.	DOCUMENT NO	REV
CABLE ASSY,160 PIN		A	21793	407408-001	. A
DRN			SHEET 10 of 17		

ENGINEERING WIRE LIST

FROM	TO	CONDUCTOR TYPE, GAUGE, COLOR	PART NO.	WIRE LENGTH	REFERENCE
MULTIPLEXER 09					
P27-A P28-A	P27-A P28-A	CABLE 2 WHT/GRN/VIO CABLE 2 WHT/BLK/BRNIRED			
P27-B P28-B	P27-B P28-B	CABLE 2 WHT/GRN/GRY CABLE 2 WHT/BLK/BRNIORN			
P27-D P28-D	P27-D P28-D	CABLE 2 WHT/BLU/GRY CABLE 2 WHT/BLK/BRNIGRN			
P27-E P28-E	P27-E P28-E	CABLE 2 WHT/VIO/GRY CABLE 2 WHT/BLK/BRNIBLU			
P25-A P26-A	P25-A P26-A	CABLE 2 WHT/ORN/YEL CABLE 2 WHT/YEL/GRN			
P25-B P26-B	P25-B P26-B	CABLE 2 WHT/ORN/GRN CABLE 2 WHT/YEL/BLU			
P25-D P26-D	P25-D P26-D	CABLE 2 WHT/ORN/VIO CABLE 2 WHT/YEL/GRY			
P25-E P2&E	P25-E P26-E	CABLE 2 WHT/ORN/GRY CABLE 2 WHT/GRN/BLU			
P25-C P26-C	P25-C P26-C	CABLE 2 WHT/ORN/BLU CABLE 2 WHT/YEL/VIO			
RACAL Instruments, Inc., 4 Goodyear St., Irvine, CA 92618					
DOCUMENT TITLE		SIZE	CODE NO.	DOCUMENT NO	REV
CABLE ASSY,160 PIN		A	21793	407408-001	. A
DRN			SHEET 11 of 17		

ENGINEERING WIRE LIST

FROM	TO	CONDUCTOR TYPE, GAUGE, COLOR	PART NO.	WIRE LENGTH	REFERENCE
P23-A P24-A	P23-A P24-A	CABLE 2 WHT/BRN/GRN CABLE 2 WHT/RED/YEL			
P23-B P24-B	P23-B P24-B	CABLE 2 WHT/BRN/BLU CABLE 2 WHT/RED/GRN			
P23-D P24-D	P23-D P24-D	CABLE 2 WHT/BRN/GRY CABLE 2 WHT/RED/VIO			
P23-E P24-E	P23-E P24-E	CABLE 2 WHT/RED/ORN CABLE 2 WHT/RED/GRY			
P21-A P22-A	P21-A P22-A	CABLE 2 WHT/BLK/RED CABLE 2 WHT/BLK/VIO			
P21-B P22-B	P21-B P22-B	CABLE 2 WHT/BLK/ORN CABLE 2 WHT/BLK/GRY			
P21-D P22-D	P21-D P22-D	CABLE 2 WHT/BLK/GRN CABLE 2 WHT/BRN/ORN			
P21-E P22-E	P21-E P22-E	CABLE 2 WHT/BLK/BLU CABLE 2 WHT/BRN/YEL			
P23-C P24-C	P23-C P24-C	CABLE 2 WHT/BRN/VIO CABLE 2 WHT/RED/BLU			
P19-C P2-C	P19-C P20-C	CABLE 2 WHT/RED CABLE 2 WHT/VIO			
P22-C P21-C	P22-C P21-C	CABLE 2 WHT/BRN/RED CABLE 2 WHT/BLK/YEL			
RACAL Instruments, Inc., 4 Goodyear St., Irvine, CA 92618					
DOCUMENT TITLE		SIZE	CODE NO.	DOCUMENT NO	REV
CABLE ASSY,160 PIN		A	21793	407408-001	. A
DRN			SHEET 12 of 17		

ENGINEERING WIRE LIST

FROM	TO	CONDUCTOR TYPE, GAUGE, COLOR	PART NO.	WIRE LENGTH	REFERENCE
P19-A P20-A	P19-A P20-A	CABLE 2 WHT/BLK CABLE 2 WHT/GRN			
P19-B P20-B	P19-B P20-B	CABLE 2 WHT/BRN CABLE 2 WHT/BLU			
P19-D P20-D	P19-D P20-D	CABLE 2 WHT/ORN CABLE 2 WHT/GRY			
P19-E P20-E	P19-E P20-E	CABLE 2 WHT/YEL CABLE 2 WHT/BLK/BRN			
P17-A P18-A	P17-A P18-A	CABLE 2 BLK CABLE 2 GRN			
P17-B P18-B	P17-B P18-B	CABLE 2 BRN CABLE 2 BLU			
P17-D P18-D	P17-D P18-D	CABLE 2 ORN CABLE 2 GRY			
P17-E P18-E	P17-E P18-E	CABLE 2 YEL CABLE 2 WHT			
P17-C P18-C	P17-C P18-C	CABLE 2 RED CABLE 2 VIO			

RACAL Instruments, Inc., 4 Goodyear St., Irvine, CA 92618

DOCUMENT TITLE	SIZE	CODE NO.	DOCUMENT NO	REV
CABLE ASSY,160 PIN	A	21793	407408-001	. A
DRN			SHEET 13 of 17	

ENGINEERING WIRE LIST

FROM	TO	CONDUCTOR TYPE, GAUGE, COLOR	PART NO.	WIRE LENGTH	REFERENCE
P15-A P16-A	P15-A P16-A	CABLE 2 WHT/BLK/ORN/VIO CABLE 2 WHT/BLK/YEL/GRY			
P15-B P16-B	P15-B P16-B	CABLE 2 WHT/BLK/ORN/GRY CABLE 2 WHT/BLK/GRN/BLU			
P15-D P16-D	P15-D P16-D	CABLE 2 WHT/BLK/YEL/BLU CABLE 2 WHT/BLK/GRN/GRY			
P15-E P16-E	P15-E P16-E	CABLE 2 WHT/BLK/YEL/VIO CABLE 2 WHT/BLK/BLU/VIO			
P13-A P14-A	P13-A P14-A	CABLE 2 WHT/BLK/BRN/VIO CABLE 2 WHT/BLK/RED/VIO			
P13-B P14-B	P13-B P14-B	CABLE 2 WHT/BLK/BRN/GRY CABLE 2 WHT/BLK/RED/GRY			
P13-D P14-D	P13-D P14-D	CABLE 2 WHT/BLK/RED/GRN CABLE 2 WHT/BLK/ORN/GRN			
P13-E P14-E	P13-E P14-E	CABLE 2 WHT/BLK/RED/BLU CABLE 2 WHT/BLK/ORN/BLU			
P15-C P16-C	P15-C P16-C	CABLE 2 WHT/BLK/YEL/GRN CABLE 2 WHT/BLK/GRN/VIO			
P11-C P12-C	P11-C P12-C	CABLE 2 WHT/BLU/VIO CABLE 2 WHT/BLK/BRN/YEL			
P14-C P13-C	P14-C P13-C	CABLE 2 WHT/BLK/ORN/YEL CABLE 2 WHT/BLK/RED/YEL			
RACAL Instruments, Inc., 4 Goodyear St., Irvine, CA 92618					
DOCUMENT TITLE		SIZE	CODE NO.	DOCUMENT NO	REV
CABLE ASSY,160 PIN		A	21793	407408-001	. A
DRN			SHEET 14 of 17		

ENGINEERING WIRE LIST

FROM	TO	CONDUCTOR TYPE, GAUGE, COLOR	PART NO.	WIRE LENGTH	REFERENCE
P11-A P12-A	P11-A P12-A	CABLE 2 WHT/GRN/VIO CABLE 2 WHT/BLK/BRN/RED			
P11-B P12-B	P11-B P12-B	CABLE 2 WHT/GRN/GRY CABLE 2 WHT/BLK/BRN/ORN			
P11-D P12-D	P11-D P12-D	CABLE 2 WHT/BLU/GRY CABLE 2 WHT/BLK/BRN/GRN			
P11-E P12-E	P11-E P12-E	CABLE 2 WHT/VIO/GRY CABLE 2 WHT/BLK/BRN/BLU			
P9-A P10-A	P9-A P10-A	CABLE 2 WHT/ORN/YEL CABLE 2 WHT/YEL/GRN			
P9-B P10-B	P9-B P10-B	CABLE 2 WHT/ORN/GRN CABLE 2 WHT/YEL/BLU			
P9-D P10-D	P9-D P10-D	CABLE 2 WHT/ORN/VIO CABLE 2 WHT/YEL/GRY			
P9-E P10~E	P9-E P10-E	CABLE 2 WHT/ORN/GRY CABLE 2 WHT/GRN/BLU			
P9-C P10-C	P9-C P10-C	CABLE 2 WHT/ORN/BLU CABLE 2 WHT/YEL/VIO			

RACAL Instruments, Inc., 4 Goodyear St., Irvine, CA 92618

DOCUMENT TITLE	SIZE	CODE NO.	DOCUMENT NO	REV
CABLE ASSY,160 PIN	A	21793	407408-001	. A
	DRN		SHEET 15 of 17	

ENGINEERING WIRE LIST

FROM	TO	CONDUCTOR TYPE, GAUGE, COLOR	PART NO.	WIRE LENGTH	REFERENCE
P7-A P8-A	P7-A P8-A	CABLE 2 WHT/BRN/GRN CABLE 2 WHT/RED/YEL			
P7-B P8-B	P7-B P8-B	CABLE 2 WHT/BRN/BLU CABLE 2 WHT/RED/GRN			
P7-D P8-D	P7-D P8-D	CABLE 2 WHT/BRN/GRY CABLE 2 WHT/RED/VIO			
P7-E P8-E	P7-E P8-E	CABLE 2 WHT/RED/ORN CABLE 2 WHT/RED/GRY			
P5-A P6-A	P5-A P6-A	CABLE 2 WHT/BLK/RED CABLE 2 WHT/BLK/VIO			
P5-B P6-B	P5-B P6-B	CABLE 2 WHT/BLK/ORN CABLE 2 WHT/BLK/GRY			
P5-D P6-D	P5-D P6-D	CABLE 2 WHT/BLK/GRN CABLE 2 WHT/BRN/ORN			
P5-E P6-E	P5-E P6-E	CABLE 2 WHT/BLK/BLU CABLE 2 WHT/BRN/YEL			
P7-C P8-C	P7-C P8-C	CABLE 2 WHT/BRN/VIO CABLE 2 WHT/RED/BLU			
P3-C P4-C	P3-C P4-C	CABLE 2 WHT/RED CABLE 2 WHT/VIO			
P6-C P5-C	P6-C P5-C	CABLE 2 WHT/BRN/RED CABLE 2 WHT/BLK/YEL			
RACAL Instruments, Inc., 4 Goodyear St., Irvine, CA 92618					
DOCUMENT TITLE		SIZE	CODE NO.	DOCUMENT NO	REV
CABLE ASSY,160 PIN		A	21793	407408-001	. A
DRN			SHEET 16 of 17		

ENGINEERING WIRE LIST

FROM	TO	CONDUCTOR TYPE, GAUGE, COLOR	PART NO.	WIRE LENGTH	REFERENCE
P3-A P4-A	P3-A P4-A	CABLE 2 WHT/BLK CABLE 2 WHT/GRN			
P3-B P4-B	P3-B P4-B	CABLE 2 WHT/BRN CABLE 2 WHT/BLU			
P3-D P4-D	P3-D P4-D	CABLE 2 WHT/ORN CABLE 2 WHT/GRY			
P3-E P4-E	P3-E P4-E	CABLE 2 WHT/YEL CABLE 2 WHT/BLK/BRN			
P1-A P2-A	P1-A P2-A	CABLE 2 BLK CABLE 2 GRN			
P1-B P2-B	P1-B P2-B	CABLE 2 BRN CABLE 2 BLU			
P1-D P2-D	P1-D P2-D	CABLE 2 ORN CABLE 2 GRY			
P1-E P2-E	P1-E P2-E	CABLE 2 YEL CABLE 2 WHT			
P1-C P2-C	P1-C P2-C	CABLE 2 RED CABLE 2 VIO			
RACAL Instruments, Inc., 4 Goodyear St., Irvine, CA 92618					
DOCUMENT TITLE		SIZE	CODE NO.	DOCUMENT NO	REV
CABLE ASSY,160 PIN		A	21793	407408-001	. A
DRN				SHEET 17 of 17	

This page was left intentionally blank.

Chapter 5

PRODUCT SUPPORT

Product Support

Racal Instruments has a complete Service and Parts Department. If you need technical assistance or should it be necessary to return your product for repair or calibration, call 1-800-722-3262. If parts are required to repair the product at your facility, call 1-949-859-8999 and ask for the Parts Department.

When sending your instrument in for repair, complete the form in the back of this manual.

For worldwide support and the office closes to your facility, refer to the Support Offices section on the following page.

Reshipment Instructions

Use the original packing material when returning the 1260-138A to Racal Instruments for calibration or servicing. The original shipping crate and associated packaging material will provide the necessary protection for safe reshipment.

If the original packing material is unavailable, contact Racal Instruments Customer Service for information.

Support Offices

RACAL INSTRUMENTS

United States

(Corporate Headquarters and Service Center)
4 Goodyear Street, Irvine, CA 92618
Tel: (800) 722-2528, (949) 859-8999; Fax: (949) 859-7139

5730 Northwest Parkway Suite 700, San Antonio, TX 78249
Tel: (210) 699-6799; Fax: (210) 699-8857

Europe

(European Headquarters and Service Center)
18 Avenue Dutartre, 78150 LeChesnay, France
Tel: +33 (0)1 39 23 22 22; Fax: +33 (0)1 39 23 22 25

29-31 Cobham Road, Wimborne, Dorset BH21 7PF, United Kingdom
Tel: +44 (0) 1202 872800; Fax: +44 (0) 1202 870810

Via Milazzo 25, 20092 Cinisello B, Milan, Italy
Tel: +39 (0)2 6123 901; Fax: +39 (0)2 6129 3606

Technologie Park, Friedrich Ebert Strasse, 51429 Bergisch Gladbach, Germany
Tel: +49 (0) 2204 844200; Fax: +49 (0) 2204 844219

REPAIR AND CALIBRATION REQUEST FORM

To allow us to better understand your repair requests, we suggest you use the following outline when calling and include a copy with your instrument to be sent to the Racal Instrument Repair Facility.

Model _____ Serial No. _____ Date _____

Company Name _____ Purchase Order # _____

Billing Address _____

City

State/Province

Zip/Postal Code

Country

Shipping Address _____

City

State/Province

Zip/Postal Code

Country

Technical Contact _____ Phone Number () _____

Purchasing Contact _____ Phone Number () _____

1. Describe, in detail, the problem and symptoms you are having. Please include all set up details, such as input/output levels, frequencies, waveform details, etc.

2. If problem is occurring when unit is in remote, please list the program strings used and the controller type.

3. Please give any additional information you feel would be beneficial in facilitating a faster repair time (i.e., modifications, etc.)

4. Is calibration data required? Yes No (please circle one)

Call before shipping Ship instruments to nearest support office.

Note: We do not accept
"collect" shipments.